

TRANSPORTATION

1. PREPARATION FOR TRANSPORTATION

- 1) When transporting the machine, observe the various road rules, road transportation vehicle laws and vehicle limit ordinances, etc.
- 2) Select proper trailer after confirming the weight and dimension from the chapter 2, specification.
- 3) Check the whole route such as the road width, the height of bridge and limit of weight and etc., which will be passed.
- 4) Get the permission from the related authority if necessary.
- 5) Prepare suitable capacity of trailer to support the machine.

- 6) Prepare gangplank for safe loading referring to the below table and illustration.

A	B
1.0	3.65 ~ 3.85
1.1	4.00 ~ 4.25
1.2	4.35 ~ 4.60
1.3	4.75 ~ 5.00
1.4	5.10 ~ 5.40
1.5	5.50 ~ 5.75

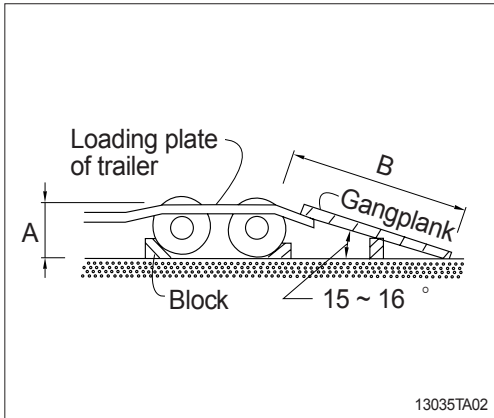
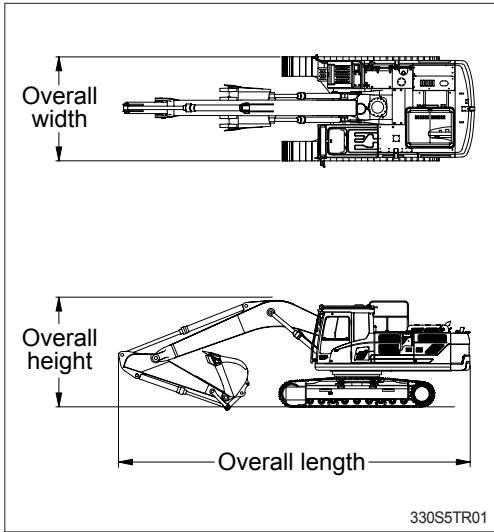

2. DIMENSION AND WEIGHT

1) HX360L

(1) Base machine

Mark	Description	Unit	Specification
L	Length	mm (ft-in)	5975 (19' 7")
H	Height	mm (ft-in)	3145 (10' 4")
W	Width	mm (ft-in)	3280 (10' 9")
Wt	Weight	kg (lb)	26785 (59051)

※ With 600 mm (24") triple grouser shoes and 6000 kg (13230 lb) counterweight.

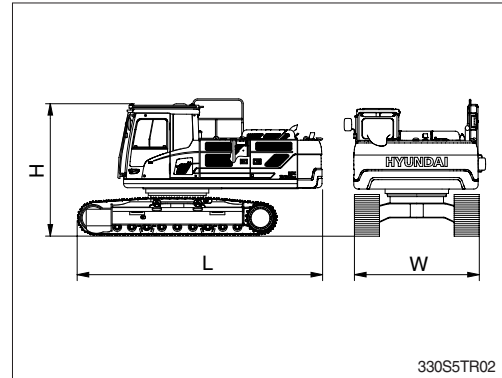

(2) Boom assembly

Mark	Description	Unit	Specification
L	Length	mm (ft-in)	6670 (21'11")
H	Height	mm (ft-in)	1720 (5' 8")
W	Width	mm (ft-in)	785 (2' 7")
Wt	Weight	kg (lb)	2940 (6482)

※ 6.45 m (21' 2") boom with arm cylinder (included piping and pins).

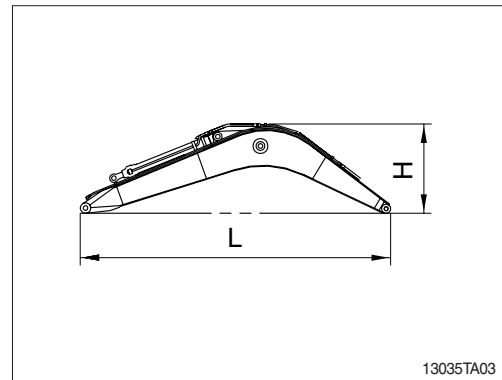

(3) Arm assembly

Mark	Description	Unit	Specification
L	Length	mm (ft-in)	4340 (14' 3")
H	Height	mm (ft-in)	955 (3' 2")
W	Width	mm (ft-in)	435 (1' 5")
Wt	Weight	kg (lb)	1435 (3163)

※ 3.2 m (10' 6") arm with bucket cylinder (included linkage and pins).

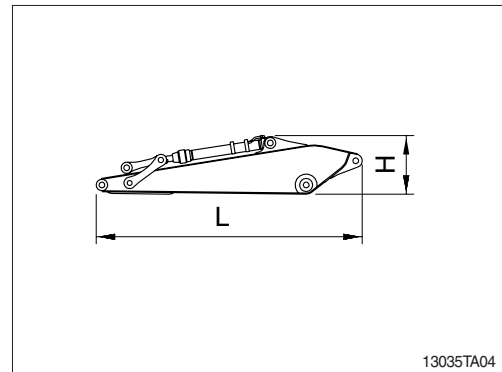

(4) Bucket assembly

Mark	Description	Unit	Specification
L	Length	mm (ft-in)	1840 (6' 0")
H	Height	mm (ft-in)	1120 (3' 8")
W	Width	mm (ft-in)	1535 (5' 0")
Wt	Weight	kg (lb)	1230 (2710)

※ 1.44 m³ (1.88 yd³) SAE heaped bucket (included tooth and side cutters).

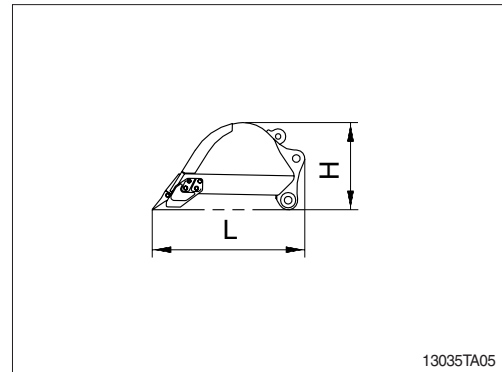

(5) Boom cylinder

Mark	Description	Unit	Specification
L	Length	mm (ft-in)	1960 (6' 5")
H	Height	mm (ft-in)	230 (0' 9")
W	Width	mm (ft-in)	330 (1' 1")
Wt	Weight	kg (lb)	314.1(692.4)

※ Included piping.

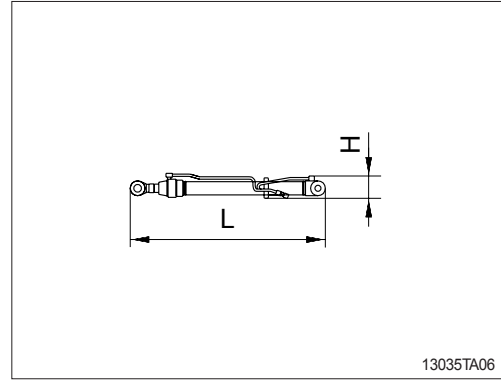

(6) Cab assembly

Mark	Description	Unit	Specification
L	Length	mm (ft-in)	1950 (6' 5") [2070 (6' 10")]
H	Height	mm (ft-in)	1780 (5' 10") [1822 (6' 0")]
W	Width	mm (ft-in)	1104 (3' 7") [1126 (3' 8")]
Wt	Weight	kg (lb)	421.8 (930) [650.2 (1433)]

[] : with FOG GUARD

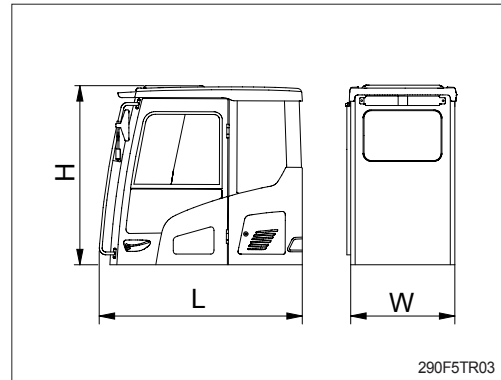

(7) Counterweight

Mark	Description	Unit	Specification
L	Length	mm (ft-in)	2980 (9' 9")
H	Height	mm (ft-in)	1250 (4' 1")
W	Width	mm (ft-in)	590 (1' 11")
Wt	Weight	kg (lb)	6000 (13230)

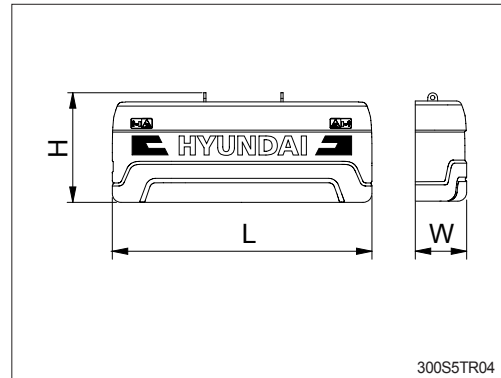

3. LOADING THE MACHINE

- 1) Load and unload the machine on a flat ground.
- 2) Use the gangplank with sufficient length, width, thickness and gradient.
- 3) Place the swing lock/fine switch to the LOCK position (if equipped) before fixing the machine at the bed of trailer and confirm if the machine parallels the bed of trailer.
Keep the travel motor in the rear when loading and in the front when unloading.

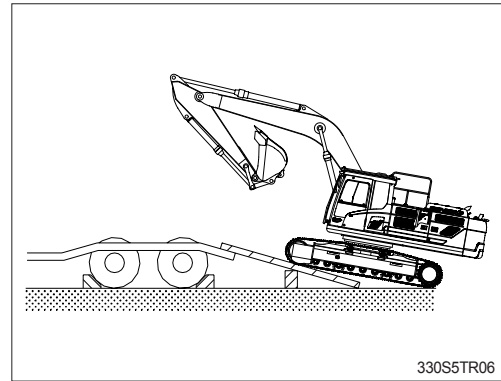

- 4) Do the following after loading the machine to the trailer.
 - (1) Stop loading when the machine is located horizontally with the rear wheel of trailer.

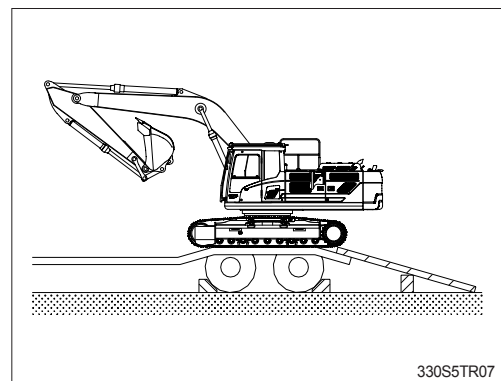

- (2) Place the swing lock/fine switch to the LOCK position (if equipped) after the swing the machine 180 degree.

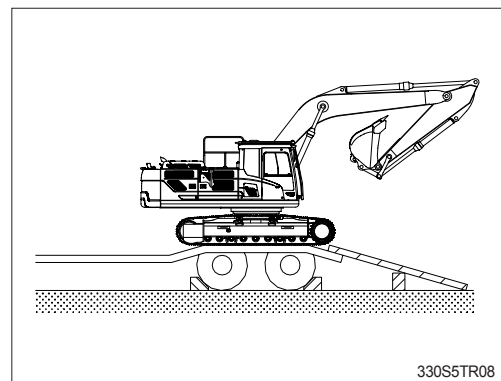

- (3) Lower the working equipment gently after the location is determined.
- ※ Place rectangular timber under the bucket cylinder to prevent the damage of it during transportation.
 - ▲ Be sure to keep the travel speed switch on the LOW (turtle mark) while loading and unloading the machine.
 - ▲ Avoid using the working equipment for loading and unloading since it will be very dangerous.
 - ▲ Do not operate any other device when loading.
 - ▲ Be careful on the boundary place of loading plate or trailer as the balance of machine will abruptly be changed on the point.

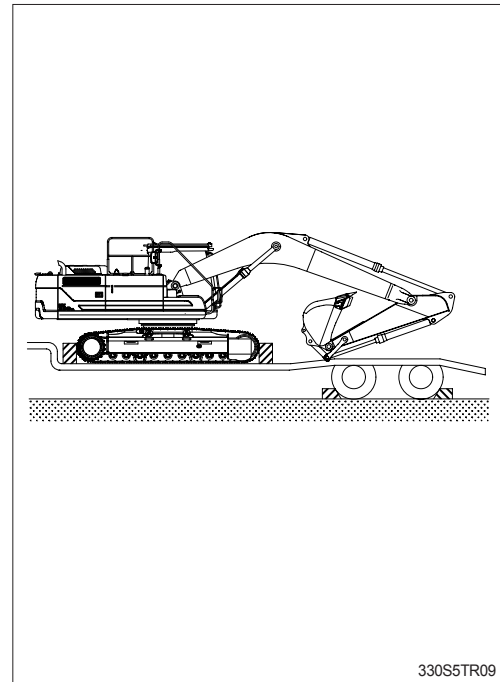

4. FIXING THE MACHINE

- 1) Lower down the working device on the loading plate of trailer.
- 2) Keep the safety lever on the LOCK position.
- 3) Turn OFF all the switches and remove the key.

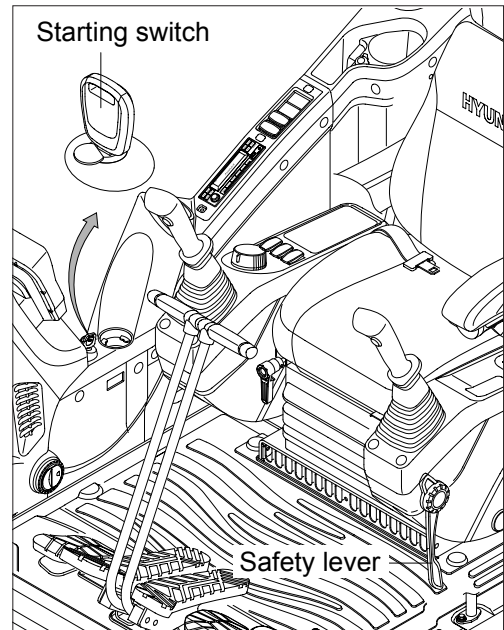

- 4) Secure all locks.

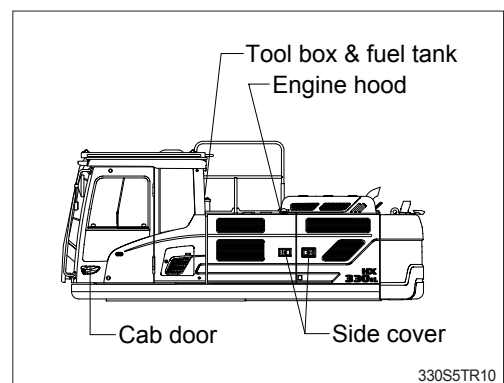

- 5) Place timber underneath of the track and fix firmly with wire rope to prevent the machine from moving forward, backward, right or left.

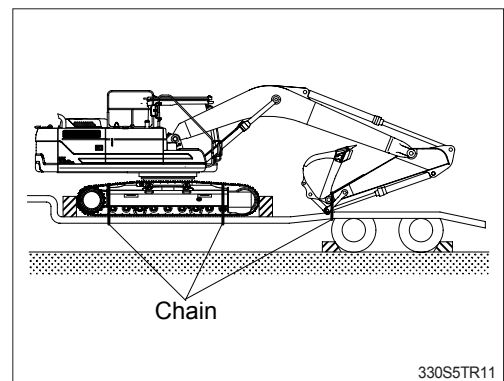

5. LOADING AND UNLOADING BY CRANE

- 1) Check the weight, length, width and height of the machine referring to the chapter 2, specification when you are going to hoist the machine.
- 2) Use long wire rope and stay to keep the distance with the machine as it should avoid touching with the machine.
- 3) Put a rubber plate contact with wire rope and machine to prevent damage.
- 4) Place crane on the proper place.
- 5) Install the wire rope and stay like the illustration.

- ▲ **Make sure wire rope is proper size.**
- ▲ **Place the safety lever to LOCK position to prevent the machine moving when hoisting the machine.**
- ▲ **The wrong hoisting method or installation of wire rope can cause damage to the machine.**
- ▲ **Do not load abruptly.**
- ▲ **Keep area clear of personnel.**

